

10 9 8 7 6 5 4 3 2 1

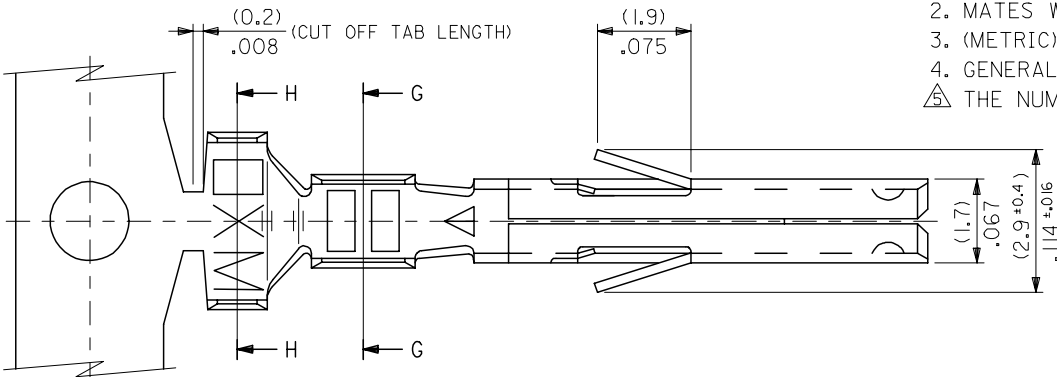

NOTES

1. APPLICABLE HOUSING : 5557 SERIES.
 2. MATES WITH TERMINAL : 5558, 5566, 5569 SERIES.
 3. (METRIC) VALUES SHOWN GOVERN OVER ENGLISH CONVERSION VALUES.
 4. GENERAL TOLERANCES OF ENGLISH CONVERSION VALUES : ±.008 INCH.
- △ THE NUMBER OF SERRATIONS TO BE ONE FOR WIRE RANGE #22-28.

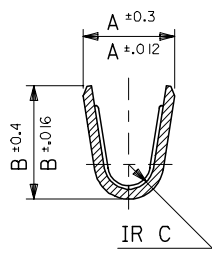
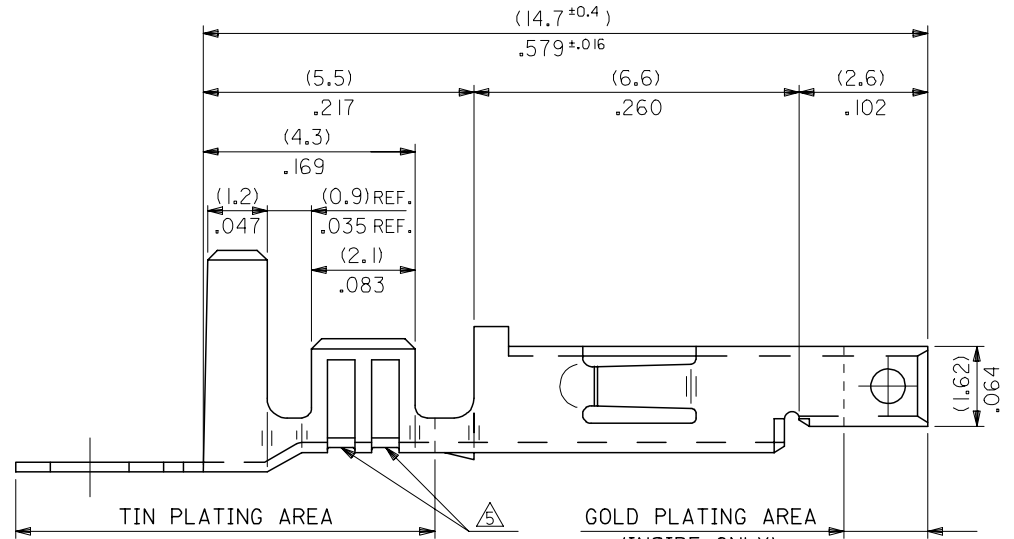

SECT. G-G

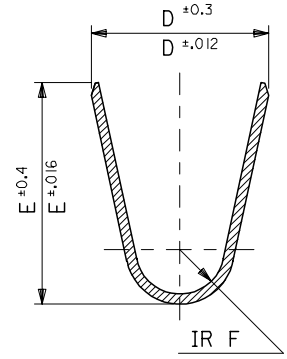

SECT. H-H

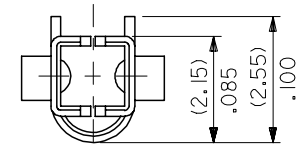

5556**GS**
MODEL NO.

REVISED EC NO: J2005-2571 DRAWN: SUZUKI 2005/03/25 CHKD: K1010 2005/03/29 APPR: NUKITA 2005/03/29 G REV	GENERAL TOLERANCES (UNLESS SPECIFIED)		DIMENSION STYLE MM ONLY		SCALE 10:1	DESIGN UNITS METRIC	THIRD ANGLE PROJECTION		
	10 UNDER	±0.2	DRAWN BY HHIRAMOT		DATE '91/05/18	TITLE NEW MINI FIT CONN CRIMP RECEPTACLE -LEAD FREE-			
	10 OVER 30 UNDER	±0.25	CHECKED BY MFUKUSHI		DATE '98/11/09				
	30 OVER	±0.3	APPROVED BY MENOMOTO		DATE '98/11/09	MOLEX INCORPORATED			
	ANGULAR ±3 °		MATERIAL NO.		DOCUMENT NO. SD-5556-006				
DRAFT WHERE APPLICABLE MUST REMAIN WITHIN DIMENSIONS		SIZE A3		THIS DRAWING CONTAINS INFORMATION THAT IS PROPRIETARY TO MOLEX INCORPORATED AND SHOULD NOT BE USED WITHOUT WRITTEN PERMISSION					

10 9 8 7 6 5 4 3 2 1

F

E

D

C

B

A

F

E

D

C

B

A

PHOSPHOR BRONZE	SELECTIVE GOLD (0.76μm)/30m.i. MIN. AND SELECTIVE TIN (2.54μm)/100m.i. MIN. OVER NICKEL (1.27μm)/50m.i. MIN.	(0.9) .035	(4.5) .177	(3.6) .142	(0.6) .024	(2.7) .106	(2.3) .091	∅ (3.1) .122 MAX.	# 16	39-00-0158 ↑ -0157	5556 PBGS3L ↑ PBGS3	LOOSE CHAIN	
		(0.6) .024	(2.3) .091	(2.3) .091	(0.4) .016	(1.65) .065	(1.8) .071	∅ (0.9-1.8) .035-.071	#22-28	-0156 -0155	PBGS2L PBGS2	LOOSE CHAIN	
		(0.9) .035	(4.5) .177	(3.6) .142	(0.5) .020	(2.3) .091	(1.9) .075	∅ (1.3-3.1) .051-.122	#18-24	-0154 -0153	PBGS L PBGS	LOOSE CHAIN	
		(0.9) .035	(4.5) .177	(3.6) .142	(0.5) .020	(2.3) .091	(1.9) .075	∅ (1.3-3.1) .051-.122	#18-24	-0441 -0440	GS IOL7F GS I07F	LOOSE CHAIN	
	SELECTIVE GOLD (1.27μm)/50m.i. MIN. AND SELECTIVE TIN (2.54 μm)/100 m.i. MIN. OVER NICKEL (1.27μm)/50m.i. MIN. ©	(0.9) .035	(4.5) .177	(3.6) .142	(0.6) .024	(2.7) .106	(2.3) .091	∅ (3.1) .122 MAX.	# 16	-0142 -0141	GS9L GS9	LOOSE CHAIN	
		(0.6) .024	(2.3) .091	(2.3) .091	(0.4) .016	(1.65) .065	(1.8) .071	∅ (0.9-1.8) .035-.071	#22-28	↓ -0140	GS8L	LOOSE	
		(0.9) .035	(4.5) .177	(3.6) .142	(0.5) .020	(2.3) .091	(1.9) .075	∅ (1.3-3.1) .051-.122	#18-24	39-00-0139 40-13-0852	GS8 GS7L	CHAIN LOOSE	
		(0.9) .035	(4.5) .177	(3.6) .142	(0.5) .020	(2.3) .091	(1.9) .075	∅ (1.3-3.1) .051-.122	#18-24	40-13-0851	GS7	CHAIN	
	BRASS	SELECTIVE GOLD (0.38μm)/15m.i. MIN. AND SELECTIVE TIN (2.54 μm)/100 m.i. MIN. OVER NICKEL (1.27μm)/50m.i. MIN. ©	(0.9) .035	(4.5) .177	(3.6) .142	(0.6) .024	(2.7) .106	(2.3) .091	∅ (3.1) .122 MAX.	# 16	39-00-0094 ↑ -0093	GS6L GS6	LOOSE CHAIN
			(0.6) .024	(2.3) .091	(2.3) .091	(0.4) .016	(1.65) .065	(1.8) .071	∅ (0.9-1.8) .035-.071	#22-28	-0092 -0091	GS5L GS5	LOOSE CHAIN
			(0.9) .035	(4.5) .177	(3.6) .142	(0.5) .020	(2.3) .091	(1.9) .075	∅ (1.3-3.1) .051-.122	#18-24	-0074 -0073	GS4L GS4	LOOSE CHAIN
			(0.9) .035	(4.5) .177	(3.6) .142	(0.6) .024	(2.7) .106	(2.3) .091	∅ (3.1) .122 MAX.	# 16	-0090 -0089	GS3L GS3	LOOSE CHAIN
SELECTIVE GOLD (0.76μm)/30m.i. MIN. AND SELECTIVE TIN (2.54μm)/100m.i. MIN. OVER NICKEL (1.27μm)/50m.i. MIN.	(0.6) .024	(2.3) .091	(2.3) .091	(0.4) .016	(1.65) .065	(1.8) .071	∅ (0.9-1.8) .035-.071	#22-28	-0435 -0434	GS2L7F GS27F	LOOSE CHAIN		
	(0.9) .035	(4.5) .177	(3.6) .142	(0.5) .020	(2.3) .091	(1.9) .075	∅ (1.3-3.1) .051-.122	#18-24	↓ -0429	GSL7F	LOOSE		
									39-00-0428	5556 GS7F	CHAIN		
MATERIAL	FINISH	F	E	D	C	B	A	INS. RANGE	WIRE RANGE	EDP NO.	ENG. NO.	FORM	

REVISED EC NO: J2005-2571 DRAWN: SUZUKI 2005/03/25 CHKD: K1010 2005/03/29 APPR: NUKITA 2005/03/29	GENERAL TOLERANCES (UNLESS SPECIFIED)		DIMENSION STYLE MM ONLY		SCALE 10:1	DESIGN UNITS METRIC	THIRD ANGLE PROJECTION	
	10 UNDER	±0.2	DRAWN BY HHIRAMOT	DATE '91/05/18	TITLE NEW MINI FIT CONN CRIMP RECEPTACLE -LEAD FREE-			
	10 OVER 30 UNDER	±0.25	CHECKED BY MFUKUSHI	DATE '98/11/09				
	30 OVER	±0.3	APPROVED BY MENOMOTA	DATE '98/11/09	MOLEX INCORPORATED			
ANGULAR	±3 °	MATERIAL NO.	DOCUMENT NO.	SHEET NO.				
DRAFT WHERE APPLICABLE MUST REMAIN WITHIN DIMENSIONS		SEE CHART		SD-5556-006		2 OF 2		
THIS DRAWING CONTAINS INFORMATION THAT IS PROPRIETARY TO MOLEX INCORPORATED AND SHOULD NOT BE USED WITHOUT WRITTEN PERMISSION								